

# triton Saw Chassis Upgrade WCA400

## Contents

**A** Slide Chassis (2 parts)

**J** Side Guard (2 parts)

### Fastener Bag 1

**B** Coach Bolt (4)

**C** Washer (4)

**D** M6 Nyloc Nut (4)

**L** M5 x 8 Screw (1)

**M** M5 Nyloc Nut (3)

**N** Outer Bearing (4)

**O** Inner Bearing (4)

**P** Bearing Spacer (2)

**Q** 1 1/2" Philips-head Screw (2)

**R** 3/4" Philips-head Screw (2)

**S** 3/16" Nyloc Nut (4)

**T** Side Guard Pivots (front & rear - joined)

**U** M5x10mm Philips-head Screw (2)

### Fastener Bag 2

**E** Saw Locators (4)

**F** Clamping Knobs (4)

**G** M6 x 40mm Philips-head Screws (4)

**H** M6 Flange Nuts (4)

**I** Alignment Cams for Triton Saw

(2 sets packed in separate bag)

**K** M5 x 25 Screw (2)

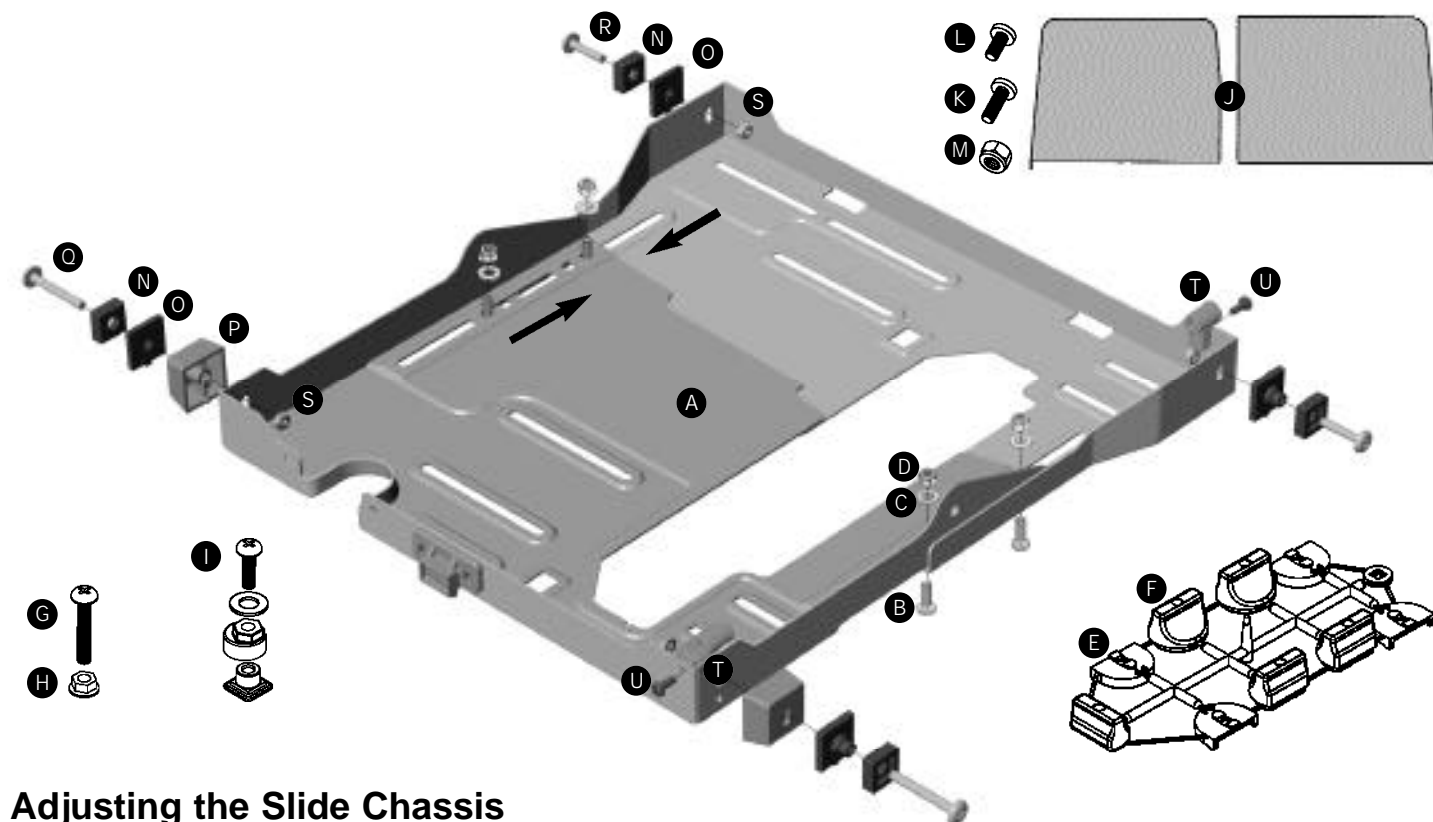

## Adjusting the Slide Chassis

Fit the two sections of the Slide Chassis (**A**) together, as shown above. Adjust the length to suit your saw baseplate (but no less than about 330mm), allowing a couple of millimetres either end for alignment of the saw. Small saws will require a spacer, as detailed on Page 3. Fit the Coach Bolts (**B**), Washers (**C**), and Nyloc Nuts (**D**), through the square holes, and tighten.

Snip apart the front and rear Side Guard Pivots (**T**). With their barrels tilting outward (away from the chassis), fit them using the M5x10mm Philips-head Screws (**U**), as shown. The screws cut their own thread.

Fit the Bearing Spacers (**P**) to the rear of the chassis (end with the red plastic catch) ensuring the locating pin engages in the hole on the chassis. Fasten the Inner Bearings (**O**) and Outer Bearings (**N**) onto the spacers using the 1 1/2" Philips-head Screws (**Q**) and 3/16" Nyloc Nuts (**S**). The tabs on the inner bearings should point down. The outer bearings are fitted with their hollow side out. Fit the remaining bearings to the front of the chassis, again ensuring the tabs point down, using the 3/4" Philips-head Screws (**R**) and Nyloc nuts. Tighten the bearing screws so they are firm, yet still free to pivot.

Place the Slide Chassis in the bearing channels with the red plastic catch and red bearing spacers closest to the front panel (the switch box end) and the flanges upwards.

Spray the channels with RP7 or WD40 for a smooth slide. Check that your saw is unplugged. Ensure the blade is adjusted square to the baseplate (0°), and set at full depth of cut.

**For fitting a saw other than the Triton 235mm Precision Power Saw, skip to Page 3.**

## Fitting the Triton Precision Power Saw

### FITTING THE SAW ALIGNMENT CAMS

Fit the Saw Alignment Cams (**I**) as shown, holding the bases in the rectangular slots while you screw into them. (The screws cut their own thread). Make sure the lines moulded on top of the cams are both pointing towards the **rear panel**. Tighten the screws until nipped gently.

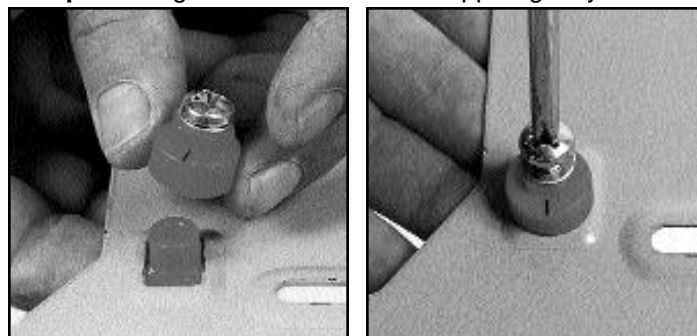

Fit the saw into the chassis with the alignment cams locating in the large holes in the saw baseplate. If necessary lengthen the chassis slightly to accommodate the cams.

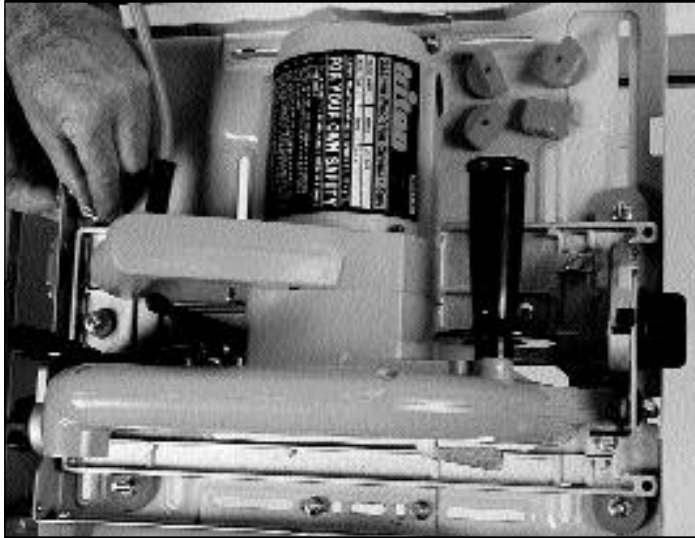

If the saw's spring-loaded guard is not held in the retracted position by the back edge of the chassis cutout tie it back with a rubber band or piece of string.

### FITTING THE SAW LOCATORS AND KNOBS

Break or cut the Saw Locators (E) and Clamping Knobs (F) from their moulding "tree" and carefully trim off any remnants with a sharp knife.

Fit the saw locators in the slots shown above, using 4 Philips-head screws (G) and Flange nuts (H). The straight sides of the locators should be facing the baseplate, but spaced away from it slightly to allow for final saw adjustment. (Use a spatula blade as shown, or a piece of cardboard or metal about 1 mm thick, as a spacer.) Firmly tighten the screws.

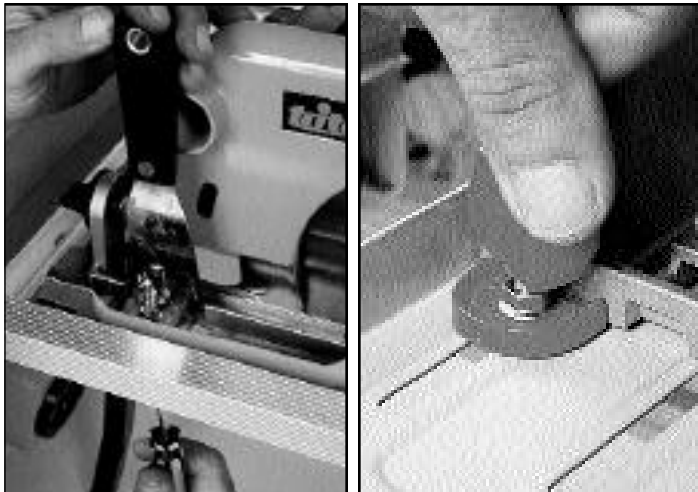

Screw the knobs on (the screws cut their own threads) until they *just* scrape against the top edge of the saw base-plate. This will hold the saw upside-down for final adjustment, and still allow it to be shifted sideways using the alignment cams. Leave the knobs with their cutaway sections facing away from the saw.

Carefully turn the slide chassis over, re-engaging the bearings in the channels. Position the chassis about halfway between the end panels.

### ALIGNING THE SAW

Adjust the fence in close to the blade and lock it. (MK3 owners should fit the table and fence for this step). Make sure the blade is vertical by comparing it to the face of the fence and adjust it if necessary, as follows: Check the

detent latch on the saw quadrant is in the up (engaged) position in the 0° detent position, and loosen the rear locking knob and the nut holding the Blade Angle Trimmer (circled below). Re-tighten the nut and rear knob after adjusting the trimmer.

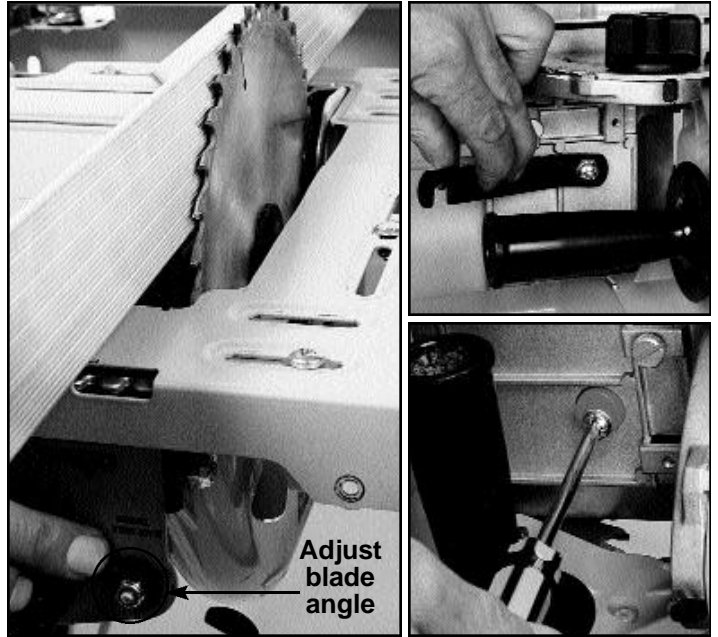

Use the saw's spanner or the Workcentre Tube Spanner to turn the cams until the front and rear of the blade are *just touching the fence*, when the fence is set at 0 mm. Then tighten the alignment cam screws as shown above. (MK3 owners should remove the table for this step).

(**HINT:** You can unscrew the front handle of the saw for better access to the front cam. Lower the blade for better access to the rear one.)

This is a very important step, because it will ensure that your saw cuts are true, and that your fence scales are accurate, so take your time.

### FINAL CLAMPING OF SAW

Double-check the saw position by now locking the fence at 0 mm, and trying to turn the blade backwards by hand. The teeth should *lightly* scrape against the face of the fence. If not, repeat the above alignment steps.

Adjust the four saw locators hard up against the edge of the baseplate, as follows: Hold each knob against turning and loosen the screw about half to one turn. Push each saw locator into position, and firmly tighten the screw.

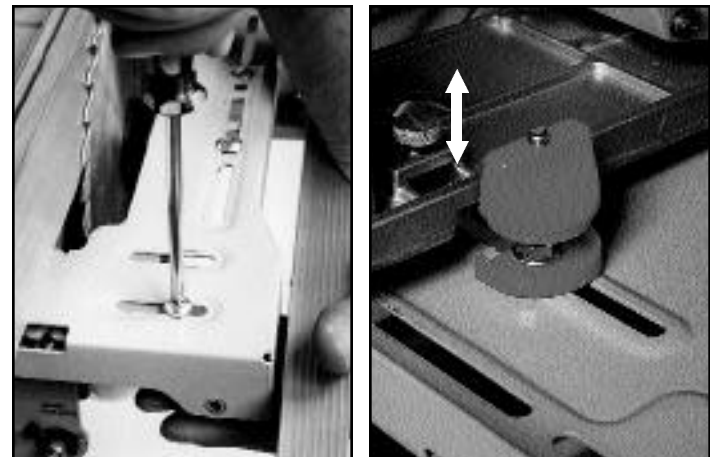

Turn the saw right-way up again and loosen the four knobs a couple of turns. Push the saw sideways to check that it cannot move, and that all screws are fully tightened. Do up the knobs again, perhaps one turn beyond when they first scrape on the baseplate.

The saw is now set up, and is available at any time for hand-held use by simply loosening each knob half a turn and lifting the saw straight up.

(**HINT:** If you tighten any one knob too much, and can't loosen it, undo the other three knobs by half a turn, remove the saw and undo the knob a little.)

## Fitting other brands of power saw

1. Position the saw as far forward as possible on the chassis, but allow for hand access to the front wing-nut or knob on the saw.
2. Don't obstruct the sawdust opening in front of the saw blade.

### For small saws:

3. Try to have the blade nut 170mm or less from the front of the chassis.
4. Bolt a thin wooden spacer (eg. 6mm ply) behind the saw to prevent possible saw movement, after the four clamps have been fitted.

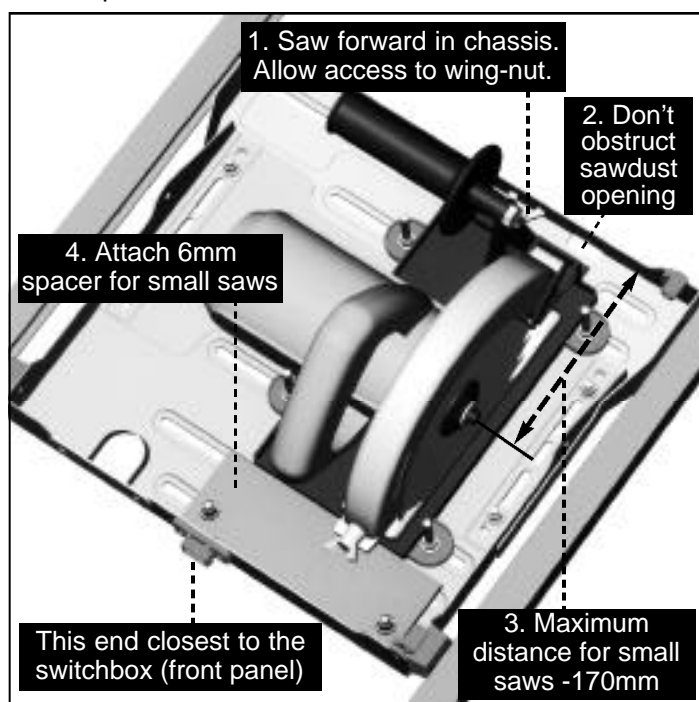

## FITTING THE SAW LOCATORS AND KNOBS

Break or cut the Saw Locators (E) and Clamping Knobs (F) off their moulding "tree", and carefully trim any remnants with a sharp knife. With the saw unplugged, retract the safety guard (you may have to temporarily tie it back) and place the saw in the chassis with the blade roughly lined up with the 3mm notches at each end of the blade slot.

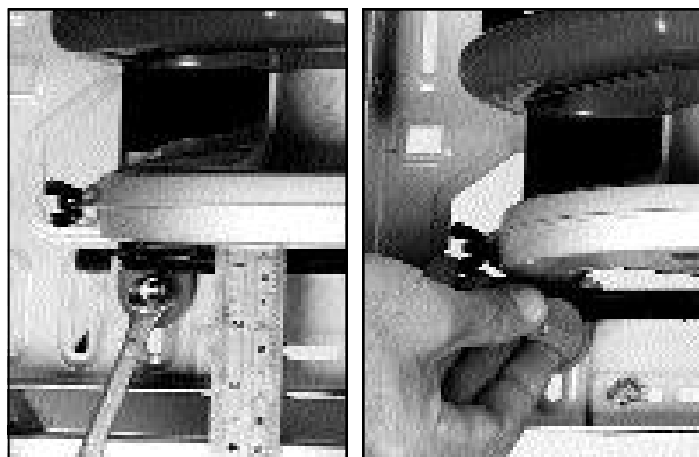

Select four widely spaced slot positions on the edge of the saw baseplate for fitting the clamps. Fit the saw locators in your selected slots with their straight sides against the base-plate using four M6 Screws (G) and Flange nuts (H). Firmly tighten up the screws using a screwdriver from below. The spanner shown below is optional, as the Flange nuts are self-gripping.

Screw the knobs on (the screws cut their own threads) until they scrape against the top edge of the saw baseplate. Leave the knobs with their cutaway sections facing away from the saw.

Check that the saw is securely clamped, and turn the slide chassis over, re-engaging the bearings in the channels.

## ALIGNING THE SAW

Hold the clamping knobs to stop them turning and use a screwdriver to loosen the clamp assemblies - *half to one turn only*.

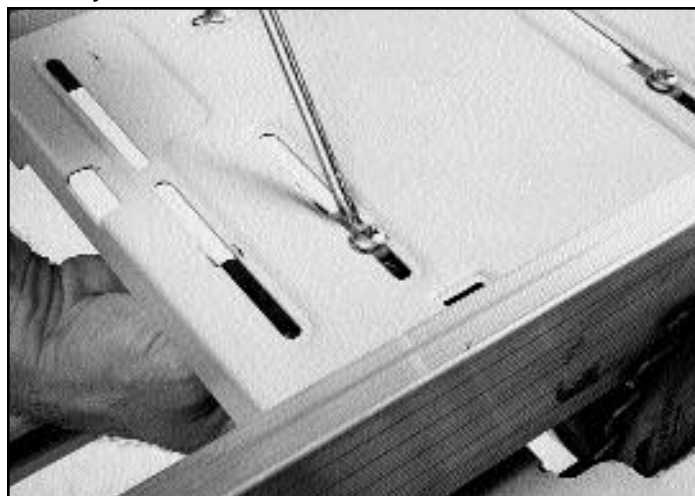

Position the chassis midway between the end panels and lock the rip fence close to the blade. (MK3 owners should fit the table and fence for this step). Compare the blade angle to the vertical face of the fence, and if necessary adjust the blade angle (using the saw's adjuster) until they are parallel vertically.

Lock the fence at 0 mm front and rear, and push the front and rear saw locators to move the saw sideways until the blade is *just touching* the fence. **Do not push the saw itself as this may dislodge the clamps.**

Spin the blade backwards by hand. The teeth should lightly scrape against the fence, when it is locked at 0 mm.

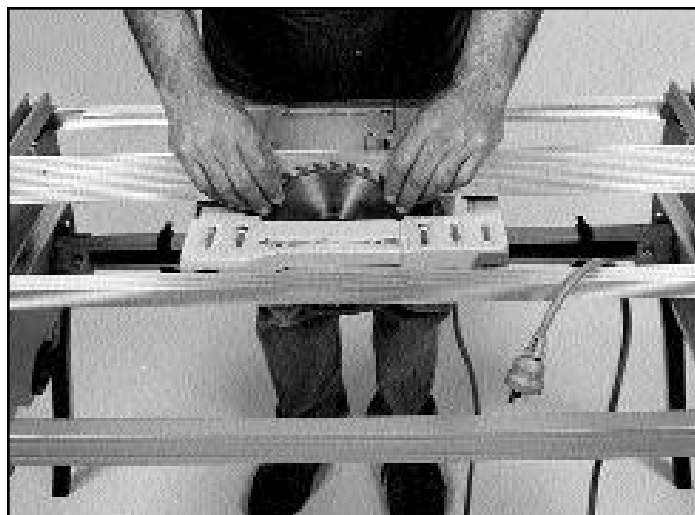

This is a very important step, it will ensure that your saw cuts are true, and that your fence scales are accurate, so take your time.

## Final clamping of saw

Check that each saw locator is pressed up against the baseplate. Hold the knobs against turning, and firmly tighten the four screws. (MK3 owners should remove the table for this step).

Back off the fence and turn the saw and chassis rightway up.

Undo the clamping knobs a couple of turns and check that you cannot move the saw baseplate sideways at all between the locators.



Do up the knobs, and this time you can tighten them a little more firmly, perhaps one turn beyond when they first scrape on the base-plate.

(**HINT:** If you tighten any one knob too much, and can't loosen it, undo the other three knobs by half a turn, remove the saw and undo the knob a little.)

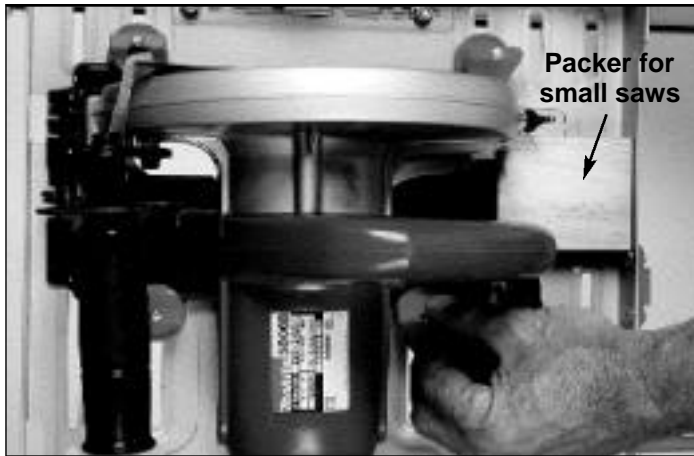

Packer for small saws

The saw is now set up, and is available at any time for hand-held use by loosening the knobs half a turn and lifting the saw straight up. If the locators are correctly fitted, the saw will go back into exactly the same position each time.

## Fitting the Saw Side Guard

Slide the two sections of the Side Guard together until they fit between the pivot brackets on the slide chassis. Loosely fit the short Philips-head screw (**K**) and a Nyloc nut (**M**) to hold the two halves together.

Fit the two longer Philips-head screws (**L**) through the pivot brackets and the guard flanges and fit the Nyloc nuts. Tighten until the guard is firm, but still free to pivot. Finally, tighten the screw holding the two halves together.

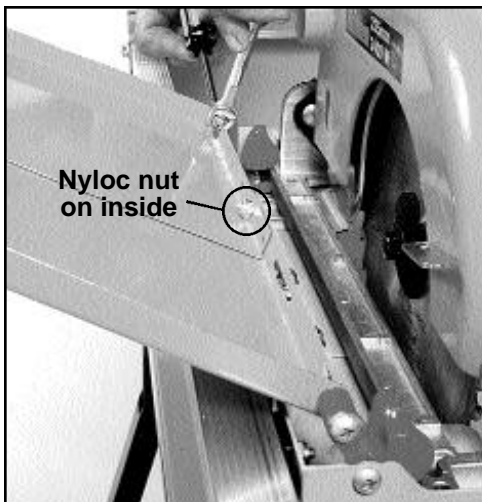

Nyloc nut on inside

## MK3 Workcentres

If fitting the Slide Chassis to a MK3 Workcentre, loosen the nuts securing the red plastic catch to the chassis. Lower the catch as far as it will go, then retighten. This allows the location tab under the table to engage in the catch.

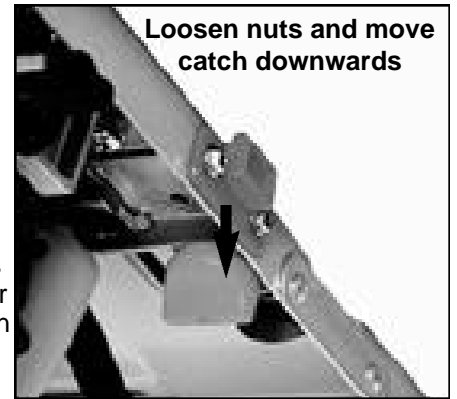

Loosen nuts and move catch downwards

## Optional Height Winder Kit (WCA390)

This slide chassis will accommodate the optional accessory Blade Height Winder (product code WCA390).

The Height Winder provides quick and precise height adjustment of your saw for precise rebates, trenches, grooves and tenons. It allows your saw to remain set at its full depth, in its most stable position.

The blade height is accurately controlled by a winder through the table, or by a hand-knob when used in the crosscut mode.

