



Dust Bag Instructions for Triton Compact

Comprises:

Elasticised dust bag
Detachable pouch

2.2m length of vacuum hose
Tapered hose connector

Bayonet hose connector

FITTING THE DUST BAG

Feed the saws power cord out through the saw motor sleeve, then fit the bag from below, ensuring the sleeve is on the same side as the motor. Stretch the elasticised bag opening around the lip on the underside of the tabletop. Hook the elastic under the notched tabs at either end of the protractor slot, as shown in the inset, to ensure the protractor is clear to slide.

Fit the sleeve securely around the saw motor and slide it along the motor as far as possible to prevent it falling off during use. The sleeve ensures a free flow of clean cooling air to the saw motor. Some saws may require the sleeve to be shortened, by rolling it back to avoid excessive material obstructing the air intake.

Fit the pouch over the stiff ring at the bottom of the dust bag and use the hook & loop tabs to tighten it into position above the ring, as shown. The bag has hook & loop openings in two of the corner seams to allow access to the saw adjustments.

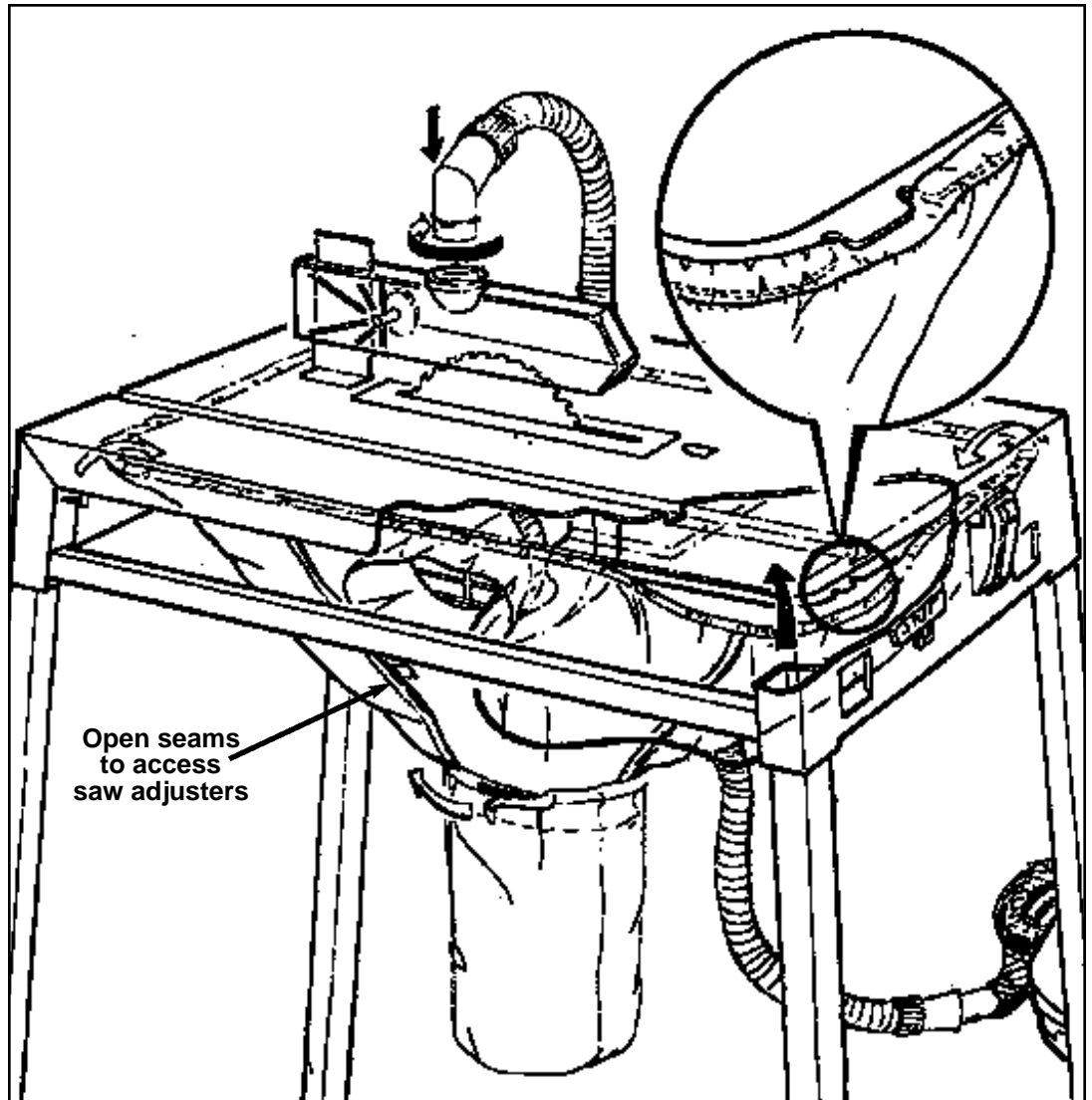

CONNECTING THE HOSE

Screw the Bayonet Hose Connector onto the Hose (note: Left-hand thread), and fit it to the dust port in the Compacts' overhead guard, as shown.

If you have a the optional Triton Dust Collector (DCA300), push fit the other end of the hose into one of the dust inlets and operate according to the Dust Collector Instructions.

If extracting dust from the overhead guard directly into your vacuum cleaner, screw the Tapered Hose Connector onto the other end of the hose and push the wand of your vacuum cleaner into it.

OPERATION

Empty your vacuum cleaner and make sure the filter and/or bags are not clogged and therefore reducing your suction. We recommend the use of the optional Triton Dust Collector (see below) to prevent the finer saw dust from potentially reaching your vacuum cleaners motor.

Before removing the pouch for emptying, tap the sides of the bag to ensure that no saw dust is caught in the top part of the bag.

If correctly fitted the system should collect close to 100% of the dust. A small amount of dust will be evident in the working area.

Planing Cuts

When making planing rip cuts on the Compact, (using the side of the blade), you will find that a lot of dust escapes.

For frequent planing cuts, we recommend you make up the baffle shown to help contain the dust. For occasional planing cuts, tape some stiff cardboard to the side of the guard, and bend it in at the front, to achieve a similar result.

For optimum performance, make sure that the baffle is sitting down on the table and that the guard is adjusted as low as possible.

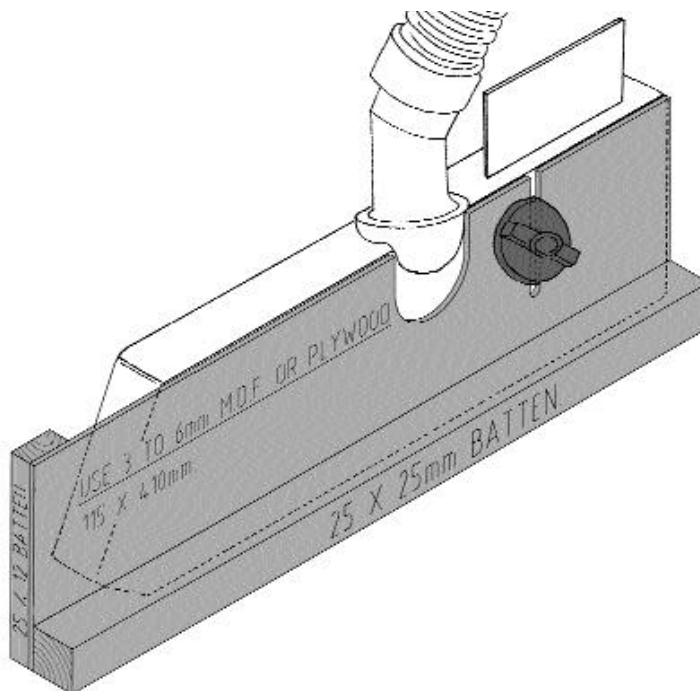

WARNINGS

Ensure the saw sleeve remains correctly fitted to the saw motor, and check it periodically, especially after saw blade height adjustments.

Do not risk overloading your fuses, extension cord and Compact switch by connecting the tool and vacuum cleaner to the same power circuit for simultaneous switching. The combined start-up amperage is excessive and could result in fusion and possibly fire. Switch the appliances on separately.

OPTIONAL TRITON DUST COLLECTOR (Product Code DCA300)

Domestic vacuum cleaners (bag-type) fill up very quickly, and the finer dust particles might damage your vacuum cleaner motor if they leak through the bag. Use the 20 litre Dust Collector between your vacuum cleaner and Compact overhead guard. There are two switchable inlets and a permanent washable filter inside the lid. Two hoses and adaptors included.

The Triton Dust Collector also suits the Triton Series 2000 Workcentre, Router Table, Biscuit Joiner, and other power tools with a dust collection point.

